

Performance Comparison of Coded and Un-Coded OFDM for Different Fec Code

Saroj Singh¹, Sagar Singh Rathore²

¹ PG Scholar, Department of Electronics & Telecommunication Bhilai, Chhattisgarh, India

²Assistant Professor, Department of Electronics & Instrumentation Bhilai, Chhattisgarh, India

Abstract-

Error correction and detection in digital communication is used to compensate the bit error rate introduced during transmission of data. In this paper the investigation has been made to the performance of some error detecting and correcting coding algorithm for OFDM system. Convolution code, RS code and linear block code based OFDM system has been implemented, studied and analyzed. Simulation is performed in MATLAB environment.

Keywords- Convolution code, Reed Solomon code, SNR, BER, AWGN ,QPSK

I. INTRODUCTION

The transmission of signal from one place to other without wire is termed as wireless communication. Now a day's wireless communication is replacing wired communication very rapidly due to its reduced cost, efficiency, flexibility, and mobility[1]. Due to its popularity, a lot of research is being done in this field to make it more and more effective for transmission [2].

The wireless communication system consist of Source, Source encoder/decoder, channel encoder/decoder, modulator/demodulator and communication channel. Source block provides the information which is to be sent. It may be speech signal, text or video. The source encoder/decoder block convert this source data into digital format. Channel encoder/decoder block[3] append some extra bit into the signal for correcting the error introduced in the signal due to fading or noise addition[4][5]or inter symbol interference[6].

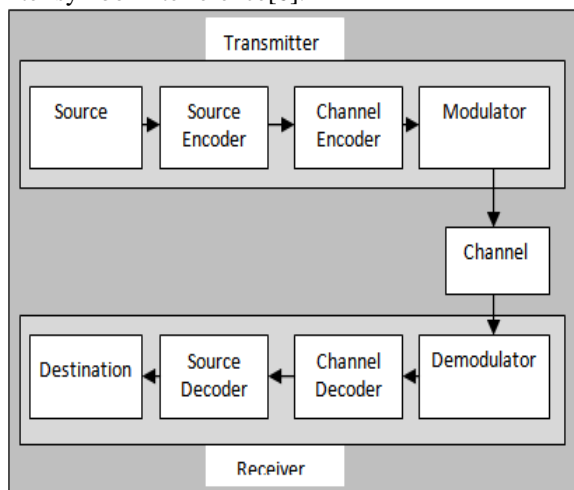

Figure 1 Wireless communication system

Modulator/demodulator block perform the modulation/ demodulation operation while the channel block represent the characteristics of communication channel like fading, interference, noise etc. Frequency division multiplexing (FDM), Time division multiplexing (TDM), Code division multiplexing(CDM)[7] are some of the multiplexing techniques used earlier in wireless communication . Later on these multiplexing were replaced by spectral efficient multiplexing technique OFDM [8]. Since in OFDM, the data of high bit stream is converted to different low bit stream data sent in parallel fashion therefore it shows better immunity over inter symbol interference (ISI). But since data is sent in different sub carrier therefore it also faces the problem of fading or multipath along with the noise. Channel coding or error correction codes [9][10] are generally used with OFDM to combat the problem of fading ,ISI and noise. A lot of various techniques have been proposed in the past for error correction [11]. It is very important for the researcher to know how these techniques perform in fading and noisy environment. This paper presents a performance evaluation of three most important error correction techniques i.e. Reed Solomon code and convolution code and linear block code [12][13][14] under fading and noisy environment.

II. CHANNEL CODER/DECODER

In order to fight the error introduce during the transmission due to multipath phenomenon, ISI and noise an appropriate coding of signal is necessary. This job is performed by the channel coder/ decoder block in communication system. Generally for coding/encoding purpose, Forward error correction code (FEC) [15]is mostly used in digital communication system. Error correction techniques generally work by introducing some redundancy

and delay in data. Parity check bit coding is one of the simplest error detection method which work by appending and extra bit at the end of each signal. Parity check bit coding is only able to detect the error it is not able to correct it moreover, it detect single bit error only and fails if more than one bit error is introduced in the signal. Coding enable us to reduce the bit error rate of the transmission while keeping the transmission rate maintained.

Block code, Convolution code, Reed Solomon code and turbo code are some of the frequently used code.

A. Reed Solomon code[15]

Reed Solomon code is a block code in which group of bits formed the block. These blocks are known as symbols. In this types of coding, a block of m-bit sequence is formed and then coding is performed on this m-bit sequence rather than individual bits. These m-bit sequences is called m-bit symbol. If any of the bit out of m-bit is changed due to noise than the entire symbol is in error. Suppose k represent the symbol information and r represent the parity symbol then the code word length of RS code is given by

$$n=k+r$$

Number of errors that can be corrected by the RS code is given by

$$t=r/2$$

RS code is a sub part of the BCH code [16] and linear in nature.

The encoding of RS code can be defined by parameters n, k, t and m which is any positive integer >2

$$(n, k)=(2^m-1, 2^m-1-2t)$$

Here t represent the capability of correcting error and number of parity symbol is represented by n-k=2t.

Generating polynomial[12] of RS code is given by following equation

$$g(X)=g_0+g_1X+g_2X^2+g_3X^3+\dots g_{2t-1}X^{2t-1}+X^{2t}$$

From here it is clear that the degree of this equation represent the number of parity symbol.

Once the encoding is accomplished then this signal is OFDM modulated and sent. At the receiver side the signal is first demodulated and then decoded to get back the original data.

The decoding procedure of Reed Solomon code is able to correct the error which is within the error correction capability of this code which is given by t

$$t=r/2=(n-k)/2$$

If the decoded codeword has error less than its error correcting capability limit then it is able to recover the original signal correctly.

If the number of errors in codeword is more than its capability then it may mis-decode and recover wrong code or may fail to decode.

The possibility of any of two cases happens depends on the Reed Solomon code used as well as the error distribution pattern and number of errors.

The decoding procedure can be of Binary or non-binary types.

But this not the case with non-binary types where need to find the location as well as the correct value of the location.

In binary decoding, only the location of error need to be found out by decoder [17]. It need not find the correct value of the location because of being a binary number it has to flipped 1 to 0 or 0 to 1.

The detail procedure of encoding and decoding of RS code is found in paper[16].

B. Linear block code[14]

Linear block code as its name suggest on the block of message. The block consist of several bits. In this type of coding, in the block of k message bits, a number of bits known as parity or check bits of (n-k) size is appended. This makes the total message bits at the output of encoder as n. This is known as (n, k block codes)[39].

In this paper the generator matrix used for code rate of 1/3, 1/2 and 2/3 is given by

$$g^{1/3} = \begin{bmatrix} 1 & 0 & 1 & 0 & 1 & 0 \\ 0 & 1 & 0 & 1 & 1 & 1 \end{bmatrix}$$

$$g^{1/2} = \begin{bmatrix} 1 & 0 & 0 & 1 & 0 & 1 \\ 0 & 1 & 0 & 1 & 1 & 0 \\ 0 & 0 & 1 & 1 & 1 & 1 \end{bmatrix}$$

$$g^{2/3} = \begin{bmatrix} 1 & 0 & 0 & 0 & 0 & 0 & 1 & 1 & 0 \\ 0 & 1 & 0 & 0 & 0 & 0 & 0 & 1 & 1 \\ 0 & 0 & 1 & 0 & 0 & 0 & 1 & 0 & 1 \\ 0 & 0 & 0 & 1 & 0 & 0 & 1 & 1 & 1 \\ 0 & 0 & 0 & 0 & 1 & 0 & 0 & 0 & 1 \\ 0 & 0 & 0 & 0 & 0 & 1 & 1 & 0 & 0 \end{bmatrix}$$

here the input for first, second and third is 2,4,6 respectively while the output as shown by these matrix are 6,6,9 respectively.

C. Convolution code[12]

Convolution coding is performed by combining the fixed number of bits in proper manner with the help of Mod-2 adder. Fixed number Shift register or memory element is used in convolution coding for storing the input bits.

III. METHODOLOGY

Block diagram of Coded OFDM simulation using Reed Solomon code is shown in the figure below. In this simulation, in the transmitter side Random number generator block generate the series of random number 1 and 0 which is fed to this

simulation as input. Channel coder block of simulation perform the appropriate encoding of the random number obtained from input block. Once the random number is encoded in to appropriate coding then the coded signal is fed to the OFDM modulator. The communication channel block is designed to introduce fading effect (Rayleigh Fading) and to add AWGN noise to the modulated OFDM symbol so that the effect of actual signal properties can be studied and analyzed. At the receiver side, the signal obtained from the communication channel block is first demodulated to get the coded OFDM demodulated signal. This function is performed by the OFDM demodulator block which is specifically designed for this very purpose. The channel decoder block takes the coded signal as input and perform the appropriate decoding operation to get back the original signal.

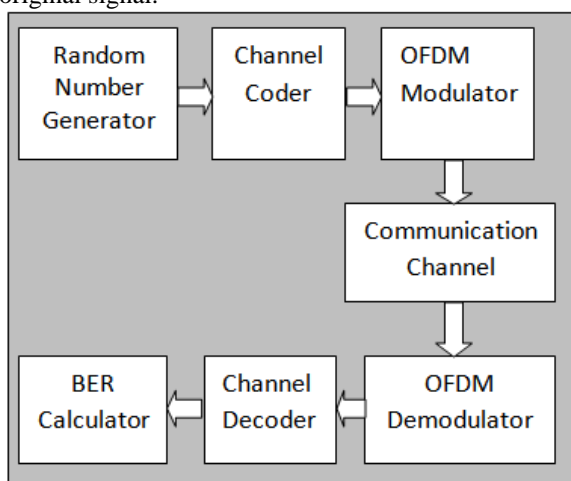

Figure 2 Block diagram of coded OFDM

BER calculator block is designed to compute the Bit error rate for different SNR and for performing Plotting operation.

IV. EXPERIMENTAL RESULTS

In order to evaluate the performance of all the three codes i.e. linear block code, RS-code, convolution code, a simulation program is designed in MATLAB software for all the three codes separately. Input data, channel fading properties as well as noise properties is kept same for all the three coding simulation. Number of carries used for ofdm system is kept 64 out of which 52 is used. Energy per bit to noise power ration is used as a performance parameter.

Rayleigh channel fading is employed for introducing fading phenomenon. While for noise, AWGN noise is generated and used. QPSK with M=4 is used for modulation purpose.

The result of simulation for linear block code is shown in graphical form in figure 3. This graph clearly shows that the channel coding improves the

BER. From the graph it is clear that the improvement in BER is obtained by decreasing the code rate. Code rate 2/3, 1/2, 1/3 shows an improvement of 4dB, 6dB and 8dB at 10^{-3} BER approximately with respect to un-coded OFDM.

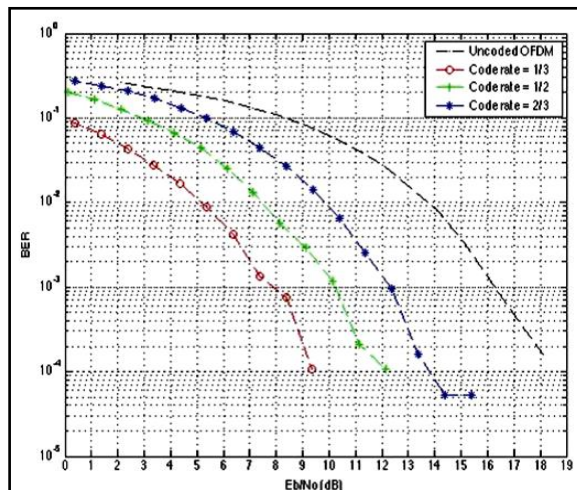

Figure 3 BER of linear block code for different code rate

The result of simulation of convolution code is plotted and shown in figure 4. From the plot it is clear that it also shows an improvement in BER as we decrease the code rate.

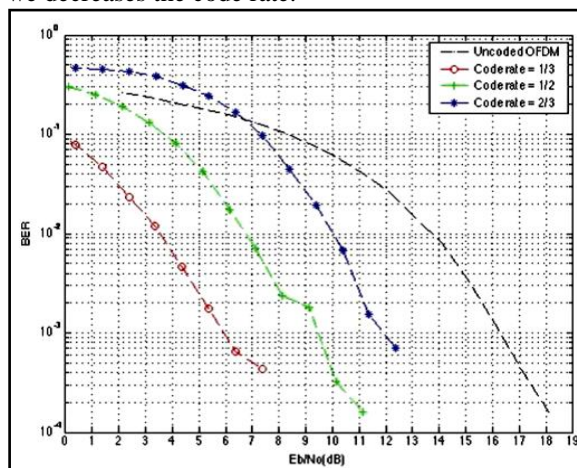

Figure 4 BER plot of convolution code for different code rate

In this case, code rate 2/3, 1/2, 1/3 shows an improvement of 4.5dB, 7dB and 10dB at 10^{-3} BER approximately with respect to un-coded OFDM. Similarly the simulation of coded OFDM with Reed Solomon code is shown in figure 5.

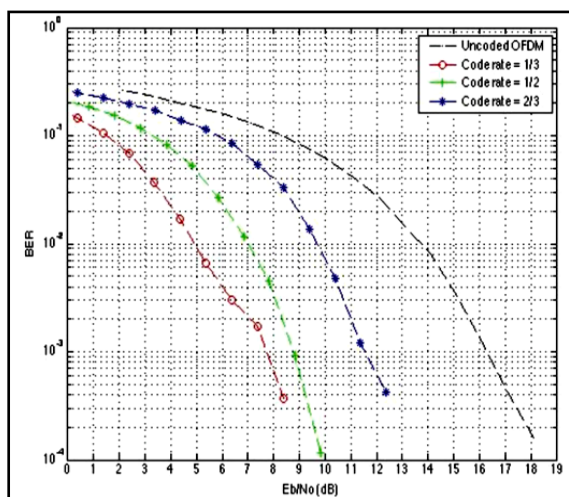

Figure 5 BER of Reed Solomon code for different code rate

The improvement in the BER with decreasing code rate is quite visible here also. For code rate 2/3, 1/2, 1/3 the improvement of 4dB, 6.5dB and 8.5dB at 10^{-3} BER is obtained with respect to un-coded OFDM.

In order to analyze more deeper, a comparison plot is also drawn for all the three coded-ofdm for same code rate.

Figure 6 depicts the comparison of all coded ofdm for 1/3 code rate. From this plot, convolution coded ofdm is clear winner which shows an improvement of 10 dB at 10^{-3} BER W.R.T. un-coded OFDM while RS code and Linear block code shows approx. same improvement.

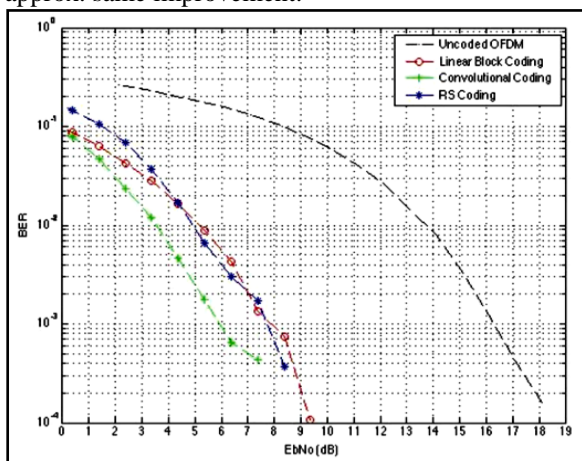

Figure 6 Comparison of Coded and un-coded OFDM for code rate 1/3

Similarly for code rate 1/2, the performance of RS coded-ofdm is better among all the three codes. Rs coded-ofdm shows an improvement of 7dB at 10^{-3} BER W.R.T. un-coded OFDM.

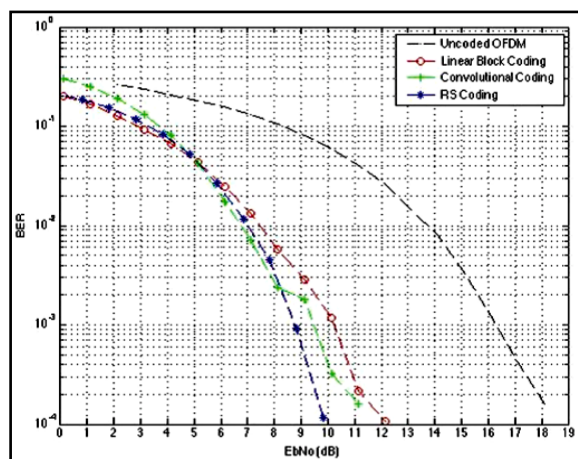

Figure 7 Comparison of Coded and un-coded OFDM for code rate 1/2

For code rate 2/3, the performance of RS-coded and Convolution coded OFDM are nearly same with RS-Coded OFDM shows little bit better performance by acquiring 5dB improvement at at 10^{-3} BER W.R.T. un-coded OFDM.

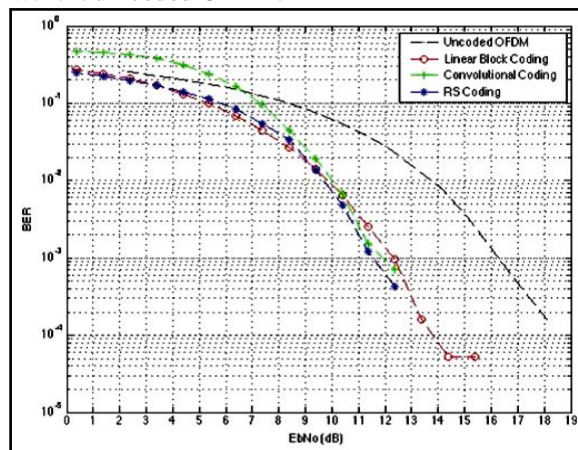

Figure 7 Comparison of Coded and un-coded OFDM for code rate 2/3

V. CONCLUSION

In this paper the comparison of linear block, Convolution and RS coded ofdm is performed and some conclusion have been drawn on the basis of simulation results and complexity. At lower code rate the performance of convolution coded ofdm is far better than rest of the two method. The problem with convolution code is that its decoding is difficult and with increase in length of data it become more complex. Linear block code is on the other hand easy to implement and from the simulation result it is evident that it gives good result for lower code rate. It is suitable for the system where low complexity is required.

Reed Solomon code is little bit difficult to implement with respect to linear block code but not as complex as convolution code. The simulation

results shows that it gives good performance for all the code rates with respect to linear block code. So the system where the requirement is high performance and low complexity, Reed Solomon coded ofdm is best.

References

- [1] Available at: <http://science.opposingviews.com/advantages-wireless-communication-1121.html>
- [2] C. Efthymiou, G. Kalogridis, Z. Fan ,” *The new frontier of communications research: smart grid and smart metering*”, 1st International Conference on Energy-Efficient Computing and Networking, USA,2010.
- [3] C. M. Nicola, “*Decoding of LDPC Codes Over Channels with Binary Additive Markov Noise*,” Queen's University Kingston, Ontario, Canada, 2005.
- [4] Wikipedia, Fading [Online] (Last modified on 22 Feb 2014). <http://en.wikipedia.org/wiki/Fading>
- [5] Wikipedia. Fading Channels [online] (Last modified on February 2013) http://en.wikibooks.org/wiki/Communication_Systems/Fading_Channels.
- [6] Y. Xiao,” *Orthogonal Frequency Division Multiplexing Modulation and inter-carrier interference cancellation*,” Louisiana State University.
- [7] Available at: http://www.gzyinxun.com/en/shownews.asp?news_id=65
- [8] S. P. Dash,” *Channel estimation in multicarrier communication system*,” National Institute of Technology Rourkela, 2009.
- [9] Hui Liu and Guoqing Li, *OFDM based Broadband Wireless Networks Design & Optimization*, WILEY, New jersey, 1-30.
- [10] Bahai, A., and B. Saltzberg. *Multicarrier Digital Communications: Theory and Applications of OFDM*. New York: Kluwer Academic/Plenum Publishers, 1999.
- [11] A. Bovik,” *The Essential guide to Image processing*”, London WC1X 8RR, UK
- [12] Wikipedia. Reed-Solomon error correction. (Last modified on 25 January 2014). http://en.wikipedia.org/wiki/Reed_solomon_codes
- [13] Wikipedia. Convolutional code. (Last modified on 26 February 2014). http://en.wikipedia.org/wiki/Convolutional_code
- [14] Wikipedia. Convolutional code. http://en.wikipedia.org/wiki/Linear_code
- [15] Taub and Schilling, “*Principles of communication systems*”, TMH second edition.
- [16] Blahut, R. E., *Theory and Practice of Error Control Codes (Reading, MA: Addison-Wesley, 1983)*.
- [17] Sklar, B., *Digital Communications: Fundamentals and Applications, Second Edition (Upper Saddle River, NJ: Prentice-Hall, 2001)*.